



DAMEN BOOSTER STATION 500

GENERAL

A containerized direct diesel driven dredge pump, radiator cooled for increasing the discharge distance.

DREDGE INSTALLATION

Dredge pump	BP5045
Impeller diameter	1,175 mm, 4 double curved vanes
Diameter suction pipe	500 mm
Diameter discharge pipe	500 mm

ENGINE INSTALLATION

Main engine	CAT 3512C
Constant power	954 kW @ 1,600 rpm
IMO certification	IMO T2
Gearbox	Reintjes, i = 2.969:1

TRANSPORT DIMENSIONS

Length over all	9.13 m
Width	2.44 m
Height	2.90 m
Max transport weight	32 ton

DREDGING INSTRUMENTATION

- Electronic vacuum and discharge pressure measurement of dredge pump;
- Optional: remote control.

REMARKABLE FEATURES

- Dredge pump equipped with mechanical seal, thus no glandwater is necessary;
- Build in a special container, rapid (de)mobilisation, provided with large doors and hatches for service;
- Easy transportation;
- Diesel engine with constant power over large speed range;
- Similar pump set as mounted on the Damen CSD500, thus limiting spares and making exchange of equipment possible.

DAMEN

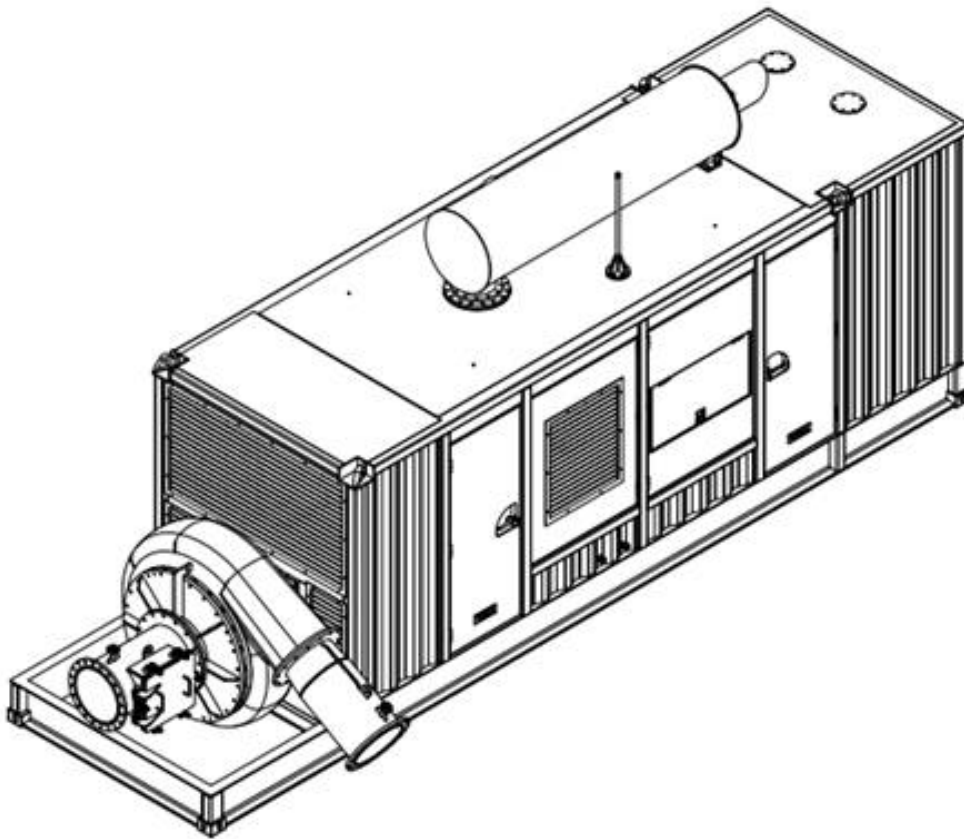
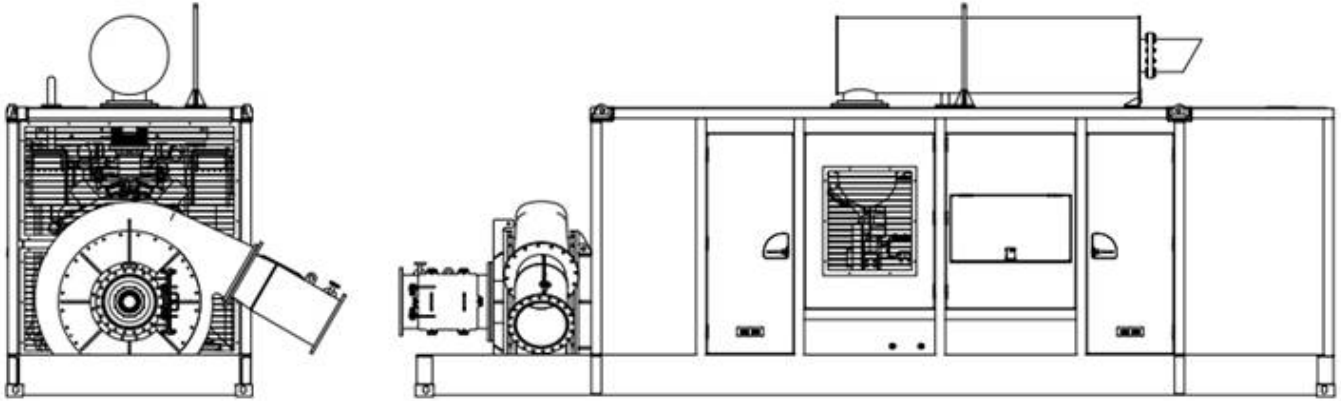

DAMEN BOOSTER STATION 500

DAMEN

DAMEN DREDGING EQUIPMENT

Member of the DAMEN SHIPYARDS GROUP



Edisonstraat 32
3861 NE Nijkerk

P.O. Box 1021
3860 BA Nijkerk
The Netherlands

phone +31 (0)33 247 40 40
fax +31 (0)33 247 40 60

info@damendredging.com
www.damendredging.com